

Istruzioni  
Instructions  
Instructions de montage  
Bedienungsanleitung  
Instrucciones



Art. 4504SF



Art. 4504SWF



Art. 4506SF



Art. 4508SF

IL MANCATO RISPETTO DELLE ISTRUZIONI ESCLUDE IL PRODUTTORE DA OGNI RESPONSABILITA'.

THE MANUFACTURER'S LIABILITY IS EXCLUDED IN CASE OF DISRESPECT OF THESE INSTRUCTIONS.

Prima dell'installazione controllare la presenza e l'integrità delle graffiature da ambo i lati.



*Before assembling the hose, please check the appropriate crimping.*

Non serrare con utensili non adatti o in punti non corretti.



*Do not tighten by inappropriate tools or in inappropriate ways.*

Dopo il montaggio evitare sollecitazioni laterali anche minime, con qualsiasi utensile.

(Es.: durante il fissaggio del tirante o astina).



*Do not expose the hose to lateral stress nor overtight by any tool.*

(Ex.: during the installation of the faucet stud or the drain pop-up lever).

Non incassare il condotto nel muro.



*Do not set the hose in the wall.*

Non installare il flessibile in torsione o in tensione.



*Tighten the hose without any twist or tension.*

Il contatto prolungato con sostanze, pur blandamente aggressive, può determinare il danneggiamento della treccia ed il conseguente scoppio del flessibile.



*Prolonged contact with any substance, even scarcely aggressive, can cause external braid damage and subsequent flexible burst.*

Avvitare i raccordi con tenuta O.R. a mano. Coppia massima di serraggio 3 Nm.



*Hand-tighten O-ring seal connectors.*  
*Max torque 3 Nm.*

Avvitare i raccordi con tenuta a guarnizione (dadi) a mano più 1/4 di giro con chiave appropriata.



*Hand-tighten connectors with gasket seal (nuts) then apply 1/4 turn using an appropriate wrench.*

**DN6 = 25 mm DN8 = 30 mm  
DN10 = 35 mm DN13 = 45 mm**

Rispettare il raggio minimo di curvatura.



*Maintain minimum bend radius.*

Prima dell'inizio della curvatura lasciare un tratto rettilineo di almeno 1,5 - 2 volte il diametro esterno.

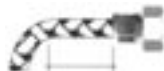

*Before bending the hose please consider a straight part of at least 1,5-2 times the external diameter.*



Non collegare la messa a terra dell'impianto elettrico al flessibile o ad altra conduttura idraulica. Chiudere l'impianto idraulico in caso di prolungata assenza. Sostituire il flessibile in caso di piccole perdite.

*Do not connect the electric grounding to the flexible hose nor to any other water piping.*  
*Turn off the plumbing in case of long absence. Replace the hose in case of leakage and anyway.*

**Art. 4504SF**

- Miscelatore monocomando lavabo con scarico automatico
- Single-lever washbasin mixer with pop-up waste
- Mitigeur lavabo avec vidage automatique
- Einhebelwaschtischmischer mit Ablaufgarnitur
- Monomando lavabo con desagus automático

**Art. 4504SWF**

- Miscelatore monocomando lavabo senza scarico
- Single-lever washbasin mixer without pop-up waste
- Mitigeur lavabo sans vidage
- Einhebelwaschtischmischer ohne ablaufgarnitur
- Monomando lavabo sin desague automatico

**Art. 4506SF**

- Miscelatore monocomando lavabo alto con scarico automatico
- High Single-lever washbasin mixer with pop-up waste
- Mitigeur lavabo sureleve avec vidage automatique
- Einhebelwaschtischmischer Hoch mit Ablaufgarnitur
- Monomando lavabo alto con desagus automático

**Art. 4508SF**

- Miscelatore monocomando bidet con scarico
- Single-lever bidet mixer with pop-up waste
- Mitigeur bidet avec vidage
- Einhebelbidetmischer mit Ablaufgarnitur
- Monomando bidé con desagus automático

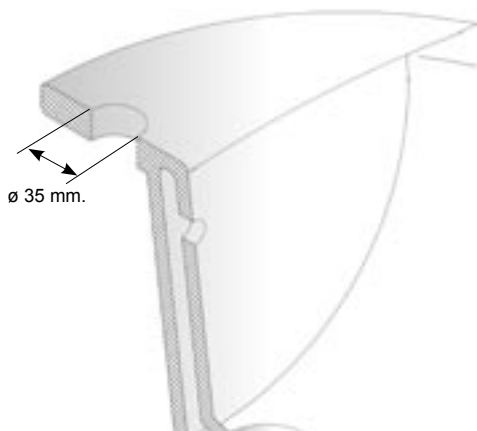
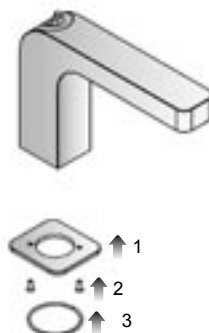
**A**

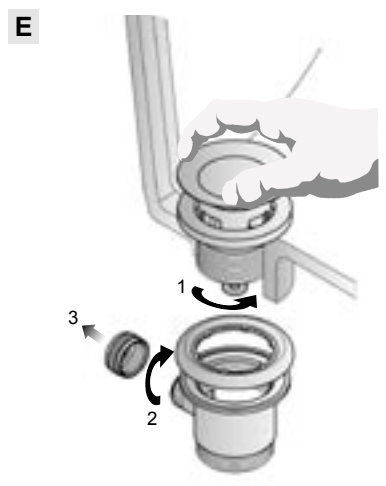
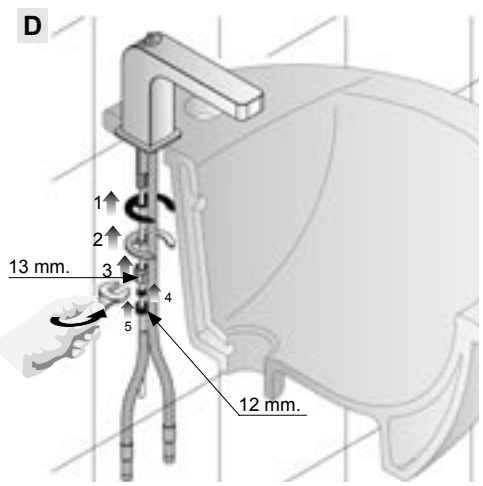
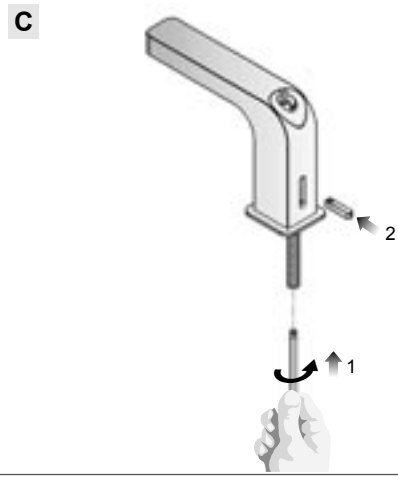
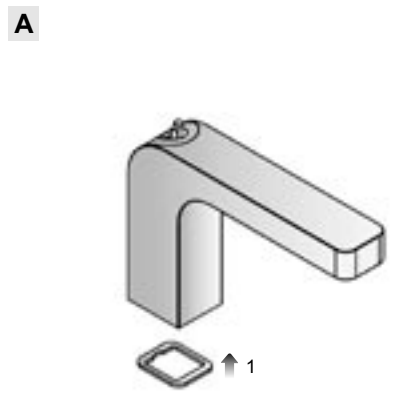
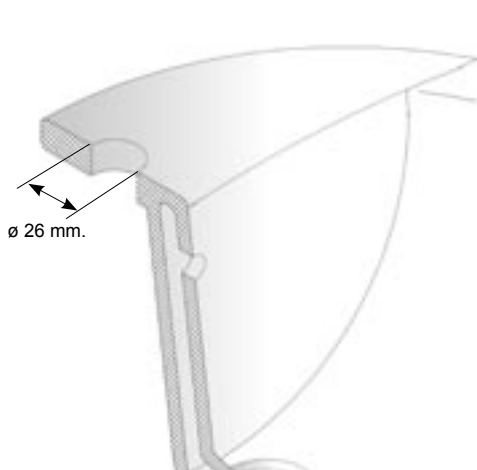

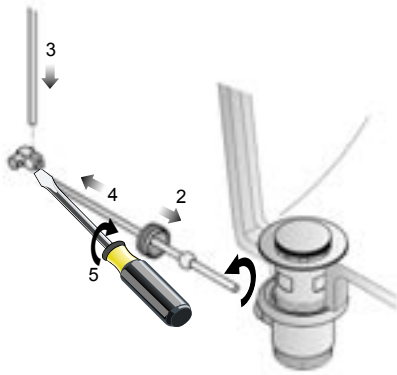
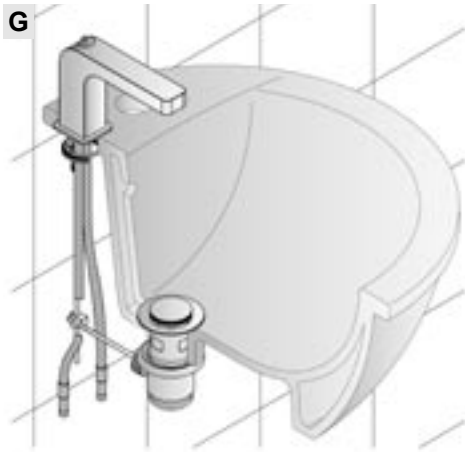
**F****G**



Art. 4548  
• Maniglia  
• Handle  
• Manette  
• Hebel  
• Maneta

A

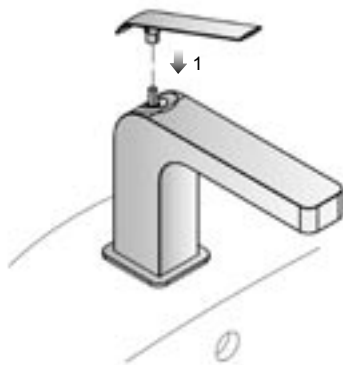

B

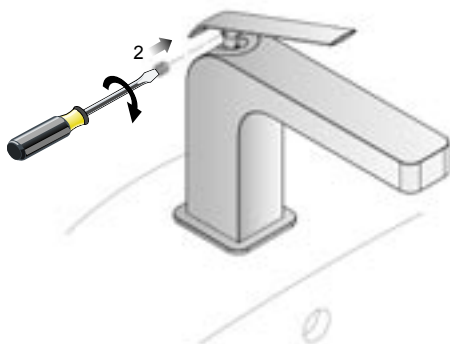

C

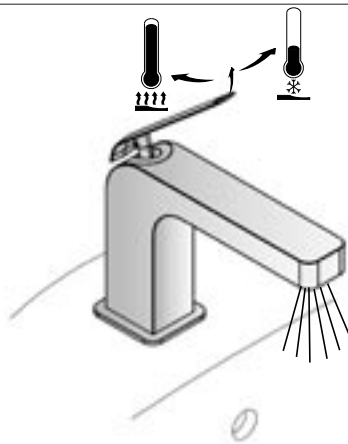



Art. 90004570

- Sostituzione cartuccia
- Cartridge replacement
- Remplacement de la cartouche
- Auswechseln der Kartusche
- Sustitucion del cartucho

A

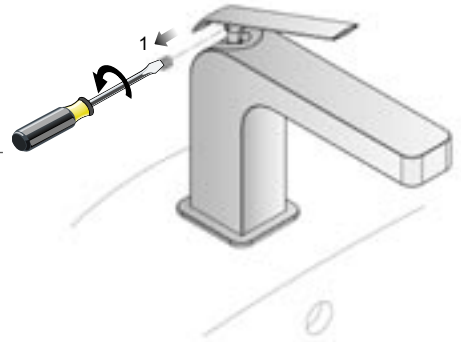

B

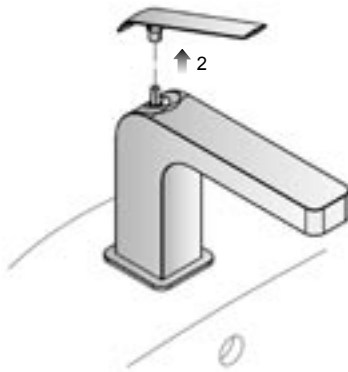

C

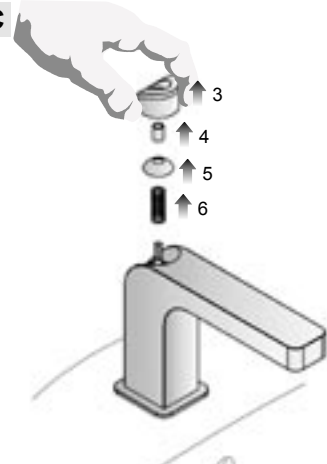

D

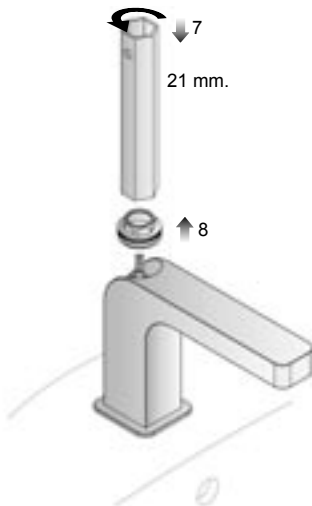

E

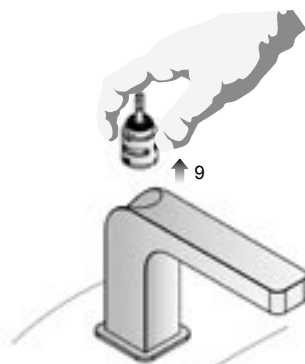

- Rimontare seguendo il procedimento inverso (E-D-C-B-A)
- Replace following the instructions in reverse order (E-D-C-B-A)
- Re-installer au contraire du procédé (E-D-C-B-A)
- Die umgekehrte Vorgehensweise folgen um die Teil wieder zu installieren (E-D-C-B-A)
- Colocar según el procedimiento inverso (E-D-C-B-A)

A

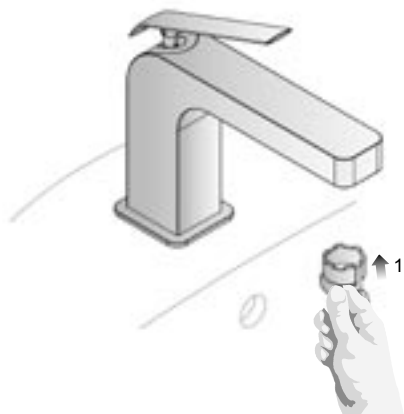

B

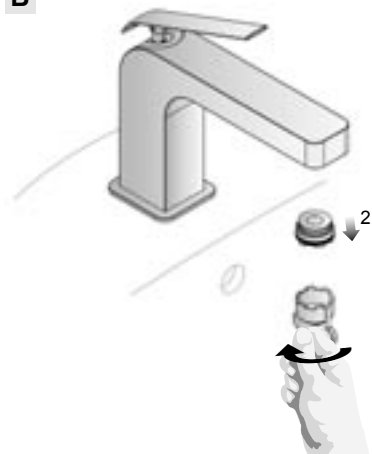

- Rimontare seguendo il procedimento inverso (B-A)
- Replace following the instructions in reverse order (B-A)
- Re-installer au contraire du procédé (B-A)
- Die umgekehrte Vorgehensweise folgen um die Teil wieder zu installieren (B-A)
- Colocar según el procedimiento inverso (B-A)

<b>Dati tecnici</b>	
PRESSIONE MINIMA.....	1 BAR
PRESSIONE MASSIMA.....	10 BAR
<b>PRESSIONE DI ESERCIZIO</b>	
CONSIGLIATA.....	2-5 BAR
TEMPERATURA MASSIMA.....	80°C
TEMPERATURA MASSIMA CONSIGLIATA.....	65°C
<b>DIFFERENZA MASSIMA DI PRESSIONE IN ARRIVO (CALDA-FREDDA).....</b>	
	1.5 BAR

**Applicazioni**

Questi miscelatori possono essere utilizzati con accumulatori di acqua calda a pressione o con scaldabagni istantanei. (SOLUZIONE NON OTTIMALE)

**Avvertenze**

Prima di installare la colonna doccia è necessario spurgare in modo accurato le tubazioni di alimentazione.  
Ricordarsi che l'acqua calda deve essere SEMPRE collegata al tubetto o flessibile di SINISTRA.

**Technische Daten**

MINIMUM DRUCK.....	1 BAR
HÖCHSTE DRUCK.....	10 BAR
<b>EMPFEHLENER DRUCK.....</b>	
HÖCHSTE WASSER TEMPERATUR.....	80°C
EMPFEHLENER HÖCHSTE WASSERTEMPERATUR.....	65°C
<b>HÖCHSTE EINKOMMENDE DRUCKUNTERSCHIED (WARM - KALT).....</b>	
	1.5 BAR

**Betriebsanweisungen**

Diese Mischer sind sowie für Heisswasserspeicher als auch für Durchlaufhitzer geeignet. (NICHT OPTIMALE LÖSUNG)

**Note**

Die Verbindungsrohre vor der Montage sorgfältig putzen.  
Das warme Wasser muss immer mit dem linken Röhrrchen oder Flexschlauch verbunden werden.

**Technical characteristics**

MINIMUM PRESSURE.....	1 BAR
MAXIMUM PRESSURE.....	10 BAR
<b>RECOMMENDED</b>	
WORKING PRESSURE.....	2-5 BAR
MAXIMUM WATER TEMPERATURE.....	80°C
MAXIMUM WATER TEMPERATURE RECOMMENDED.....	65°C
MAXIMUM IN-LET PRESSURE DIFFERENCE (HOT - COLD).....	1.5 BAR

**Operating instructions**

These mixers can be used with cumulos boilers or instantaneous water heaters. (NOT OPTIMUM SOLUTION)

**Warning**

The supplying pipes must be carefully cleaned before installation.  
Remember that the hot water supply must ALWAYS be connected to the tube on the LEFT.

**Datos Técnicos**

PRESION MÍNIMA.....	1 BAR
PRESION MÁXIMA.....	10 BAR
<b>PRESION DE TRABAJO</b>	
ACONSEJADA.....	2-5 BAR
TEMPERATURA MÁXIMA.....	80°C
TEMPERATURA MÁXIMA ACONSEJADA.....	65°C
<b>DIFERENCIAL MÁXIMA DE PRESIÓN DE ENTRADA (CALIENTE - FRÍA).....</b>	
	1.5 BAR

**Aplicaciones**

Estos monomandos pueden ser utilizados con acumuladores de agua caliente a presión. (SOLUCIÓN NON OPTIMALE)

**Advertencias**

Antes de conectar el monomando es necesario purgar correctamente la instalación hidráulica de alimentación de cualquier impureza que pueda tener.  
Recuerde que el agua caliente debe ser SIEMPRE conectada al tubo o flexo de la IZQUIERDA.

**Caractéristiques Techniques**

PRESSION MINIMUM.....	1 BAR
PRESSION MAXIMUM.....	10 BAR
<b>PRESSION OPTIMALE</b>	
DE SERVICE.....	2-5 BAR
TEMPÉRATURE MAXIMUM.....	80°C
TEMPÉRATURE MAXIMUM OPTIMALE.....	65°C
<b>DIFFÉRENCE MAXIMUM DE PRESSION D'ARRIVÉE (CHAUD - FROID).....</b>	
	1.5 BAR

**Mode d'emploi**

Ces mitigeurs peuvent être utilisés avec accumulateurs d'eau chaude à pression ou avec des chauffe-eau instantanés. (SOLUTION NON OPTIMALE)

**Note**

Il est indispensable que les raccords d'alimentation soient purgés avant la mise en place de l'appareil.  
Se rappeler que l'eau chaude doit être TOUJOURS liée au petit tuyau ou au flexible de GAUCHE.

## CURA DEL PRODOTTO

La pulizia delle superfici va fatta utilizzando un sapone liquido diluito in acqua.

Non usare mai in nessun caso detersivi liquidi contenenti sostanze abrasive o a base di acido muriatico, spugne abrasive, aceto, ammoniac, acetone, candeggina, acidi di uso domestico, disinfettanti vari.

**ATTENZIONE!** L'impiego di prodotti non consigliati può deteriorare irrimediabilmente le superfici, nel qual caso la *FANTINI S.p.A.* non risponderà del danno.

L'azienda si riserva in qualunque momento di apportare senza preavviso modifiche a prodotti e accessori. I dati riprodotti in questo documento hanno carattere informativo e non sono vincolanti.

## PFLEGE HINWEISE UNSERER ARTIKEL

Zur Reinigung empfehlen wir Wasser und flüssige Seife.

Verwenden Sie bitte nie flüssige Reinigungsmittel, die Schmirgel, Salzsäure, Essig, Ammoniak, Aceton, Bleichlange, Desinfektionsmittel u.s.w. enthalten.

**WARNUNG!** Der Gebrauch solcher Mittel kann unsere Artikel beschädigen und in diesem Fall gewährt Firma *FANTINI S.p.A.* keine Garantie.

Der Hersteller behält sich das Recht vor jederzeit Änderungen an seinen Produkten und Zubehörteilen ohne Vorbescheid vorzunehmen. Katalogangaben sowie Abbildungen, Maß- und Leistungsangaben sind unverbindlich.

## ADVICE ON PRODUCT CARE

To clean de surface use a soap and water solution.

Never use for any reason cleaning solutions containing abrasive substances, chloric acids, ammonia, varnish remoner, bleach, domestic acids, disinfectants, or anytype of abrasive pad.

**WARNING!** Incorrect cleaning may permanently ruin the surface of the products and in such case *FANTINI S.p.A.* may not be held liable for damage.

The Manufacturer reserves the right to modify product and accessories at any time without prior notice. Datas, products and sketches included in this document are just for information and do not bind the producer.

## CONSEJOS PARA EL CUIDADO DEL PRODUCTO

La limpieza de las superficies se hace utilizando un jabón liquido diluido en agua.

No usar en ningún caso detergentes líquidos que contengan sustancias abrasivas ó a base de ácido clorhídrico, estropajossabrasivos, amoniaco, acetona, lejía, ácidos de uso doméstico, desinfectantes varios.

**ATENCIÓN!** El uso de productos desaconsejados puede danar irremediabilmente las superficies de los elementos, de lo cual *FANTINI S.p.A.* no se hará responsable en ningún caso.

La sociedad se reserva el derecho de modificar sus productos y accesorios en cualquier momento y sin previo aviso.

## CONSEILS POUR L'ENTRETIEN DU PRODUIT

La poussiere en surface devra être faite en utilisant un savon liquide dilué dans l'eau.

Ne jamais utiliser en aucun cas des détergents liquides contenant des substances abrasives ou à base d'acide, nid'éponges abrasives, vinaigre, ammoniacque, acétone, eau de Javel, acides à usage domestique, désinfectants divers.

**ATTENTION!** L'empli de produits non conseillés peut détériorer irremediabilmente la surface des articles pour lesquels la société *FANTINI S.p.A.* ne sera pas responsable.

La société se réserve le droit de modifier ses produits et ses accessoires à tout moment et sans préavis. Informations, produits et croquis reproduits dans ce documents sont de nature informative et ne sont pas contractuels.





**Australian Standard**

**Installation**

Products shall be installed in accordance with AS/NZS 3500 series of standards. Installer shall ensure that the flow controlled aerator is tightened to prevent removal by hand



COMPANY  
WITH QUALITY MANAGEMENT  
SYSTEM CERTIFIED BY ISO  
=ISO 9001:2000=

FRATELLI FANTINI S.p.A.  
28010 Pella (NO) - Via M. Buonarotti, 4  
Telefono + 39 0322.918411 r.a. - Telefax + 39 0322.969530  
e-mail: [fantini@fantini.it](mailto:fantini@fantini.it)    [www.fantini.it](http://www.fantini.it)